



BAKETEK

FEV56
FEV106

Baketek line is a **complete range** of **humidified convection** ovens for **bakery** and **pastry application** capable of meeting the requests of **the most demanding professional users** in terms of performances, functionality, time and costs saving requirements.



All models are available in three different versions:
Manual (M) electromechanical controls, **Digital (E)** digital controls
Programmable (P) saving a maximum of 80 baking programs, each of them made up of max. 8 phases.

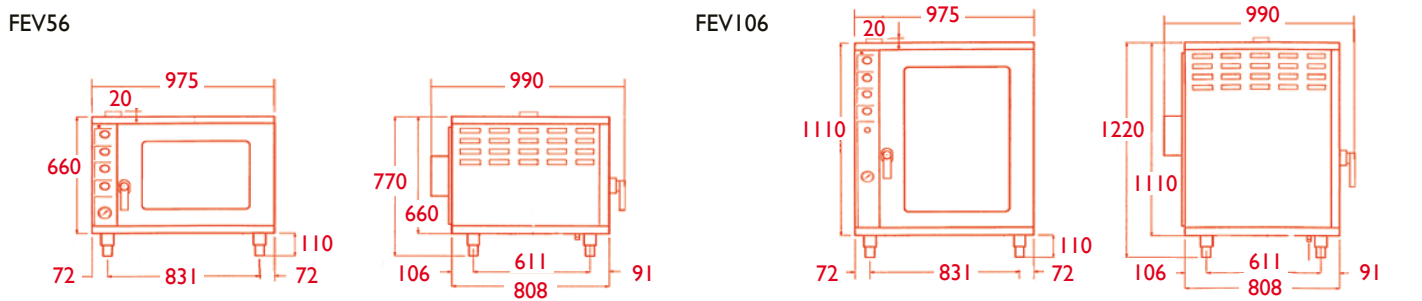

	FEV56 ⚡	FEV106 ⚡
Voltage	400V(3ph+N) 50-60Hz or on request 230V(1ph) 50-60Hz	400V(3ph+N) 50-60Hz
Power	7.9 kW	15.8 kW
Controls	M = Electromechanical E = Digital P = Programmable	M = Electromechanical E = Digital P = Programmable
Outside finishing	AISI430 stainless steel	AISI430 stainless steel
Inside finishing	AISI430 stainless steel	AISI430 stainless steel
No. of fans	1 (timed inversion)	2 (timed inversion)
Max. tray capacity and tray size	5 trays mm. 600 x 400 (2 trays included) or on request 5 trays mm. 660 x 460	10 trays mm. 600 x 400 (2 trays included) or on request 10 trays mm. 660 x 460
Tray interval	80 mm.	80 mm. (100 mm. in 8 trays capacity version)
Max. working temperature	270°C	270°C
Timer	120 min.	120 min.
Humidification	adjustable	adjustable
Dimensions (l x w x h)	975 x 990 x 790 mm.	975 x 990 x 1240 mm.
Net weight	103 Kg.	158 Kg.
Packed dimensions and weight	1010 x 1040 x 900 mm. - Kg. 120	1010 x 1040 x 1360 mm. - Kg. 178
Standard packing	export pallet box	export pallet box

Part numbers, models, descriptions and technical characteristics may be modified by IK-INTERKLIMAT S.p.A. without prior notification.



BAKETEK

Baketek line is completed by **proofers** and by a full **range of accessories** available on request.

LIEV12



LIEV13

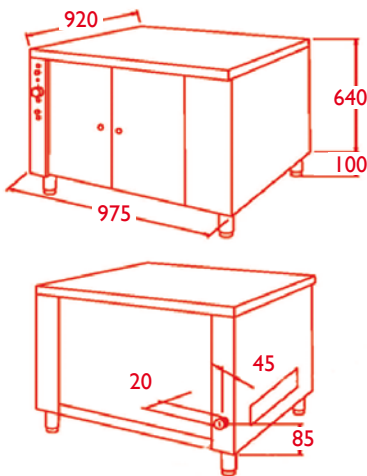

	LIEV12 ⚡	LIEV13 ⚡
Voltage	230V(1ph) 50-60Hz	230V(1ph) 50-60Hz
Power	1.4 kW	1.4 kW
Controls	electromechanical	electromechanical
Outside finishing	AISI430 stainless steel / glass doors	AISI430 stainless steel / steel doors
Inside finishing	AISI430 stainless steel	AISI430 stainless steel
Max. tray capacity and tray size	10 trays mm. 600 x 400 (not included) or on request 5 trays mm. 660 x 460	10 trays mm. 600 x 400 (not included) or on request 5 trays mm. 660 x 460
Tray interval	90 mm.	90 mm.
Working temp. range	30 - 90°C	30 - 90°C
Humidification button	YES	YES
Dimensions (l x w x h)	975 x 940 x 740 mm.	975 x 940 x 740 mm.
Net weight	52 Kg.	52 Kg.
Packed dimensions and weight	980 x 1010 x 900 mm. Kg. 70	980 x 1010 x 900 mm. Kg. 70
Standard packing	export pallet box	export pallet box

ACCESSORIES

SUP905 Baketek ovens open stand

SUP955 Tray holder for SUP905

CAPI00 Motorized aspiration hood

DVA001 Water softener

KITZOCI10 Baketek oven/proofer socle kit

600 x 400 mm. size aluminium trays:

TEG129 Level tray

TEG130 Silicone glazed level tray

TEG131 Teflon coated level tray

TEG134 Perforated level tray

TEG135 Perforated level tray - silicone glazed

TEG139 Perforated corrugated tray - 5 slots

TEG140 Perforated corrugated tray - 5 slots - silicone glazed

600 x 400 mm. size grills:

GRI295 Chromed grill



DVA001



SUP905 + 955



TEG129



CAPI00



TEG131



KITZOCI10



TEG139

Part numbers, models, descriptions and technical characteristics may be modified by IK-INTERKLIMAT S.p.A. without prior notification.

"GIERRE" is a brandname of IK-INTERKLIMAT S.p.A.

IK-Interklimat

via Remigio Paone, 2 - 20153 Milano (Italy) - tel. +39.02.452817.1 - fax +39.02.48202850
e-mail: gierre@gierre.net - ovens@ikinterklimat.com



BAKETEK

FEV57
FEV107

Baketek line is a **complete range** of **humidified convection** ovens for **bakery** and **pastry application** capable of meeting the requests of **the most demanding professional users** in terms of performances, functionality, time and costs saving requirements.



All models are available in three different versions:
Manual (M) electromechanical controls, **Digital (E)** digital controls
Programmable (P) saving a maximum of 80 baking programs, each of them made up of max. 8 phases.

FEV57

FEV107

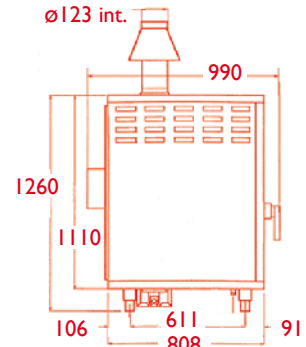
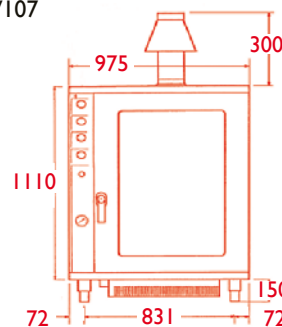
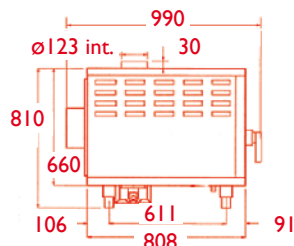
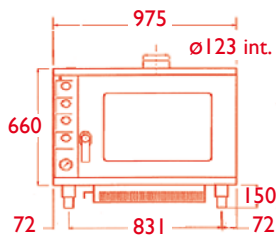

	FEV57 🔥	FEV107 🔥
Voltage	230V(1ph) 50Hz or on request 60Hz	230V(1ph) 50Hz or on request 60Hz
Power	0.4 kW	0.8 kW
Gas consumption (warm-up)	natural gas = G20 1.427 m ³ /h / LPG = G30 1.067 Kg/h	natural gas = G20 1.691 m ³ /h / LPG = G30 1.265 Kg/h
Controls	M = Electromechanical - E = Digital P = Programmable	M = Electromechanical - E = Digital P = Programmable
Outside finishing	AISI430 stainless steel	AISI430 stainless steel
Inside finishing	AISI430 stainless steel	AISI430 stainless steel
No. of fans	1 (timed inversion)	2 (timed inversion)
Max. tray capacity - tray size	5 trays mm. 600 x 400 (2 trays included) or on request 5 trays mm. 660 x 460	10 trays mm. 600 x 400 (2 trays included) or on request 10 trays mm. 660 x 460
Tray interval	80 mm.	80 mm. (100 mm. in 8 trays capacity version)
Max. working temperature	270°C	270°C
Timer	120 min.	120 min.
Humidification	adjustable	adjustable
Dimensions (l x w x h)	975 x 990 x 840 mm.	975 x 990 x 1260 mm.+300 mm. wind-protection chimney
Net weight	117 Kg.	173 Kg.
Packed dimens. and weight	1010 x 1040 x 960 mm. - Kg. 135	1010 x 1040 x 1440 mm. - Kg. 194
Standard packing	export pallet box	export pallet box

Part numbers, models, descriptions and technical characteristics may be modified by IK-INTERKLIMAT S.p.A. without prior notification.



BAKETEK

Baketek line is completed by **proofers** and by a full **range of accessories** available on request.

LIEV12



LIEV13

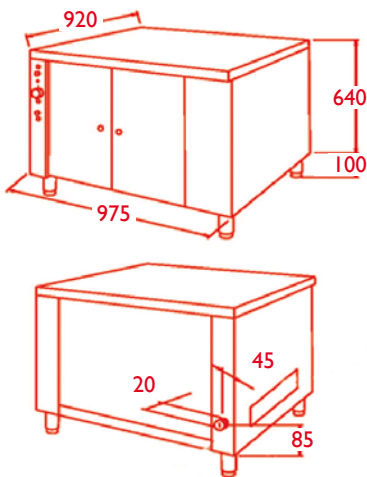

	LIEV12 ⚡	LIEV13 ⚡
Voltage	230V(1ph) 50-60Hz	230V(1ph) 50-60Hz
Power	1.4 kW	1.4 kW
Controls	electromechanical	electromechanical
Outside finishing	AISI430 stainless steel / glass doors	AISI430 stainless steel / steel doors
Inside finishing	AISI430 stainless steel	AISI430 stainless steel
Max. tray capacity and tray size	10 trays mm. 600 x 400 (not included) or on request 5 trays mm. 660 x 460	10 trays mm. 600 x 400 (not included) or on request 5 trays mm. 660 x 460
Tray interval	90 mm.	90 mm.
Working temp. range	30 - 90°C	30 - 90°C
Humidification button	YES	YES
Dimensions (l x w x h)	975 x 940 x 740 mm.	975 x 940 x 740 mm.
Net weight	52 Kg.	52 Kg.
Packed dimensions and weight	980 x 1010 x 900 mm. Kg. 70	980 x 1010 x 900 mm. Kg. 70
Standard packing	export pallet box	export pallet box

ACCESSORIES

SUP905 Baketek ovens open stand

SUP955 Tray holder for SUP905

CAP100 Motorized aspiration hood

DVA001 Water softener

KITZOCI10 Baketek oven/proofer socle kit

600 x 400 mm. size aluminium trays:

TEG129 Level tray

TEG130 Silicone glazed level tray

TEG131 Teflon coated level tray

TEG134 Perforated level tray

TEG135 Perforated level tray - silicone glazed

TEG139 Perforated corrugated tray - 5 slots

TEG140 Perforated corrugated tray - 5 slots - silicone glazed

600 x 400 mm. size grills:

GRI295 Chromed grill



DVA001



SUP905 + 955



TEG129



CAP100



TEG131



KITZOCI10



TEG139

Part numbers, models, descriptions and technical characteristics may be modified by IK-INTERKLIMAT S.p.A. without prior notification.



BAKETEK

FEVI66
FEVI68

Baketek line is a **complete range** of **humidified convection** ovens for **bakery** and **pastry application** capable of meeting the requests of **the most demanding professional users** in terms of performances, functionality, time and costs saving requirements.

FEVI66-168M



All models are available in three different versions:
Manual (M) electromechanical controls
Digital (E) digital controls
Programmable (P) saving a maximum of 80 baking programs, each of them made up of max. 8 phases

Part numbers, models, descriptions and technical characteristics may be modified by IK-INTERKLIMAT S.p.A. without prior notification

FEVI66-168 ⚡

Voltage	400V(3ph+N) 50-60Hz
Power	23.7 kW
Controls	M = Electromechanical - E = Digital - P = Programmable
Outside finishing	AISI430 stainless steel
Inside finishing	AISI430 stainless steel
No. of fans	3 (timed inversion)
Max. tray capacity and tray size	FEVI66 = accomodating trolley for max. 16 trays mm. 600 x 400 (not included) FEVI68 = accomodating trolley for max. 16 trays mm. 760 x 460 (not included)
Tray interval	n.a.
Max. working temperature	270°C
Timer	120 min.
Humidification	adjustable
Motorized aspiration hood	included on all versions
Dimensions (l x w x h)	925 x 1695 x 2150 mm.
Net weight	337 Kg.
Packed dimensions and weight	1050 x 1500 x 2260 mm. - Kg. 390
Standard packing	wooden crate



BAKETEK

FEV166-168

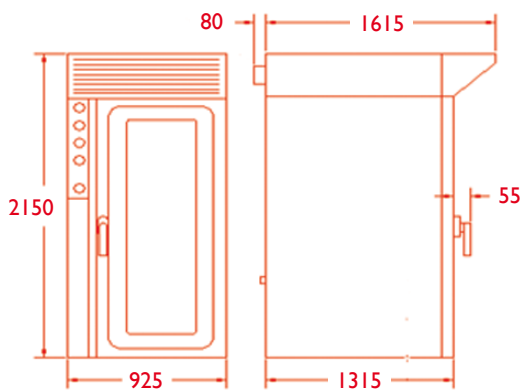

ACCESSORIES

CAR010 Trolley for max. 16 trays 600 x 400 mm. (trays not included)

CAR020 Trolley for max. 16 trays 760 x 460mm. (trays not included)

DVA001 Water softener

600 x 400 mm. size aluminium trays:

TEG129 Level tray

TEG130 Silicone glazed level tray

TEG131 Teflon coated level tray

TEG134 Perforated level tray

TEG135 Perforated level tray - silicone glazed

TEG139 Perforated corrugated tray - 5 slots

TEG140 Perforated corrugated tray - 5 slots - silicone glazed

600 x 400 mm. size grills:

GRI295 Chromed grill



CAR010 - CAR020 DVA001



TEG129



TEG131

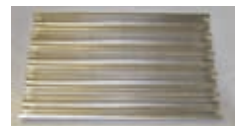

TEG139

Part numbers, models, descriptions and technical characteristics may be modified by IK-INTERKLIMAT S.p.A. without prior notification



BAKETEK

BAKE500 BAKE1000

Baketek line is a complete range of humidified convection ovens for bakery and pastry application capable of meeting the requests of the most demanding professional users in terms of performances, functionality, time and costs saving requirements. **Baketek ovens**, that during the years have turn out to be the best selling items in GIERRE production, **are today being re-styled** both in their look and **with the introduction of some major technical improvements** such as fan dual-speed and quick fan inversion.

BAKE500



BAKE1000



BAKE500

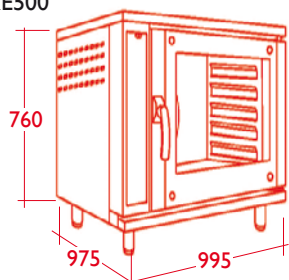

BAKE1000

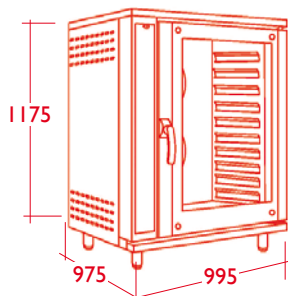

The new models **BAKE500** and **BAKE1000** are now available with electromechanical controls and digital display of temperature values.

	BAKE500UM ⚡	BAKE1000UM ⚡
Voltage	400V(3ph+N) 50-60 Hz	400V(3ph+N) 50-60 Hz
Power	7.9 kW	15.8 kW
Controls	electromechanical with digital display of temperature values	electromechanical with digital display of temperature values
Outside finishing	AISI430 stainless steel	AISI430 stainless steel
Inside finishing	AISI430 stainless steel	AISI430 stainless steel
No. of fans	1	2
Fan speed and inversion	fan timed inversion + single speed or on request fan dual-speed (50% and 100%) and quick fan inversion	fan timed inversion + single speed or on request fan dual-speed (50% and 100%) and quick fan inversion
Max. tray capacity and tray size	5 trays mm. 600 x 400 (2 trays included)	10 trays mm. 600 x 400 (2 trays included)
Tray interval	80 mm.	80 mm.
Max. working temperature	270°C	270°C
Timer	120 min.	120 min.
Humidification	adjustable	adjustable
Removable drip-collector tank	YES	YES
Dimensions (l x w x h)	995 x 975 x 760 mm. (105 - 150 mm. adjustable feet)	995 x 975 x 1175 mm. (105 - 150 mm. adjustable feet)
Net weight	110 Kg.	162 Kg.
Packed dimensions and weight	1010 x 1040 x 900 mm. - 127 Kg	1010 x 1040 x 1360 mm. - Kg. 182
Standard packing	export pallet box	export pallet box

Part numbers, models, descriptions and technical characteristics may be modified by IK-INTERKLIMAT S.p.A. without prior notification



BAKETEK BAKEIOUG

The line is completed by **BAKEIOUG proofers** and by a full **range of accessories** available on request.

BAKEIOUG

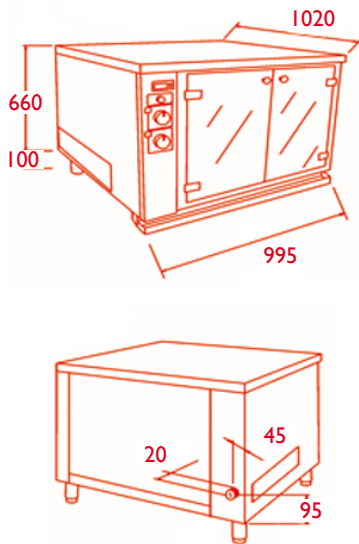

	BAKEIOUG ⚡
Voltage	230V(1ph) 50-60 Hz
Power	1.4 kW
Controls	electromechanical with digital setting of desired temperature values
Outside finishing	AISI430 stainless steel / glass doors
Inside finishing	AISI430 stainless steel
Max. tray capacity and tray size	10 trays mm. 600 x 400 (not included)
Tray interval	90 mm.
Temperature range	30 - 70°C
Timer	120 min.
Humidification	YES
Removable drip - collector tank	YES
Dimensions (l x w x h)	995 x 1040 x 760 mm. (105 - 150 mm. adjustable feet)
Net weight	68 Kg.
Packed dimensions and weight	1030 x 1110 x 860 mm. - Kg. 87
Standard packing	export pallet box

ACCESSORIES

- SUP906** Bake ovens open stand
- SUP956** Tray holder for SUP906
- DVA001** Water softener

600 x 400 mm. size aluminium trays:

- TEGI29** Level tray
- TEGI30** Silicone glazed level tray
- TEGI31** Teflon coated level tray
- TEGI34** Perforated level tray
- TEGI35** Perforated level tray - silicone glazed
- TEGI39** Perforated corrugated tray-5 slots
- TEGI40** Perforated corrugated tray-5 slots - silicone glazed

600 x 400 mm. size grills:

- GRI295** Chromed gri



DVA001



SUP906 + 956



TEGI29



TEGI31



TEGI39

Part numbers, models, descriptions and technical characteristics may be modified by IK-INTERKLIMAT S.p.A. without prior notification