



BRIOTEK

Briotek line of **convection ovens** - with and without **humidification** - is especially conceived for best performances on **croissants, pastries, bite-sized pizza, cakes** and **frozen** or **precooked bread**. They are the **ideal choice** for pubs, snack-bars, sandwich shops, pizza corners and cafeterias.

BRIO
VERNICIATO



BRIO INOX

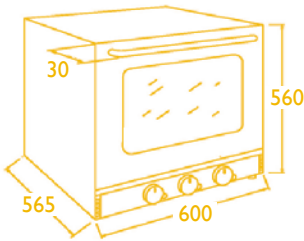

Brio and Brio Umidificato oven models ensure constant baking quality and even baking results with an eye to energy saving requirement.

Thanks to the possibility of selecting five different heating options, Brio model is a **“multifunction”** oven:

Single level traditional baking



Baking and warming-up



Baking and au-gratin



Forced convection baking



Multilevel convection baking

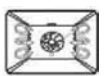

	BRIO VERNICIATO ⚡	BRIO VERNICIATO UM ⚡	BRIO INOX ⚡	BRIO INOX UM ⚡
Voltage	230V(1ph) 50-60Hz	230V(1ph) 50-60Hz	230V(1ph) 50-60Hz	230V(1ph) 50-60Hz
Power	2.7 kW	2.7 kW	2.7 kW	2.7 kW
Controls	electromechanical	electromechanical	electromechanical	electromechanical
Outside finishing	black painted	black painted	AISI430 stainless steel	AISI430 stainless steel
Inside finishing	enamel plate	enamel plate	enamel plate	enamel plate
No. of fans	1	1	1	1
Max. tray capacity and tray size	4 trays mm. 432 x 343 (included)	4 trays mm. 432 x 343 (included)	4 trays mm. 432 x 343 (included)	4 trays mm. 432 x 343 (included)
Tray interval	70 mm.	70 mm.	70 mm.	70 mm.
Max. working temperature	300°C	300°C	300°C	300°C
Timer	60 min.	60 min.	60 min.	60 min.
Humidification button		YES		YES
Dimensions (l x w x h)	600 x 595 x 560 mm.	600 x 595 x 560 mm.	600 x 595 x 560 mm.	600 x 595 x 560 mm.
Net weight	36 Kg.	36 Kg.	36 Kg.	36 Kg.
Packed dimensions and weight	660 x 650 x 630 mm. 40 Kg.	660 x 650 x 630 mm. 40 Kg.	660 x 650 x 630 mm. 40 Kg.	660 x 650 x 630 mm. 40 Kg.
Standard packing	carton on pallet	carton on pallet	carton on pallet	carton on pallet

Part numbers, models, descriptions and technical characteristics may be modified by IK-INTERKLIMAT S.p.A. without prior notification.



BRIOTEK

Each Briotek oven model can be equipped with matching **proofers**.

LIEV09



LIEV10

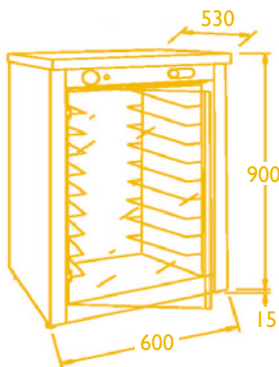

	LIEV09 ⚡	LIEV10 ⚡
Voltage	230V(1ph) 50-60Hz	230V(1ph) 50-60Hz
Power	1.4 kW	1.4 kW
Controls	electromechanical	electromechanical
Outside finishing	black painted glass door	AISI430 stainless steel glass door
Inside finishing	black painted	AISI430 stainless steel
Max. tray capacity and tray size	9 trays mm. 432 x 343 (not included)	9 trays mm. 432 x 343 (not included)
Tray interval	70 mm.	70 mm.
Working temperature range	30 - 90°C	30 - 90°C
Dimensions (l x w x h)	600 x 530 x 915 mm.	600 x 530 x 915 mm.
Net weight	27 Kg.	27 Kg.
Packed dimensions and weight	650 x 600 x 990 mm. 31 Kg.	650 x 600 x 990 mm. 31 Kg.
Standard packing	carton on pallet	carton on pallet

ACCESSORIES



GRI302
Chromed grill mm. 432 x 343



TEG239
Aluminium tray mm. 432 x 343

Part numbers, models, descriptions and technical characteristics may be modified by IK-INTERKLIMAT S.p.A. without prior notification.



BRIOTEK

Briotek line of **convection ovens** - with and without **humidification** - is especially conceived for best performances on **croissants, pastries, bite-sized pizza, cakes** and **frozen or precooked bread**. They are the **ideal choice** for pubs, snack-bars, sandwich shops, pizza corners and cafeterias.

BRIO MIDI



BRIO MAXI

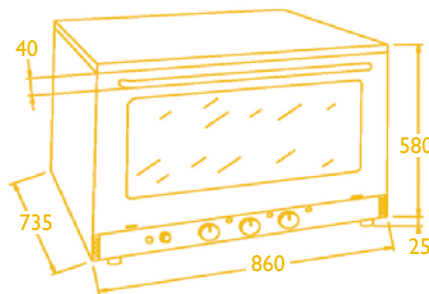
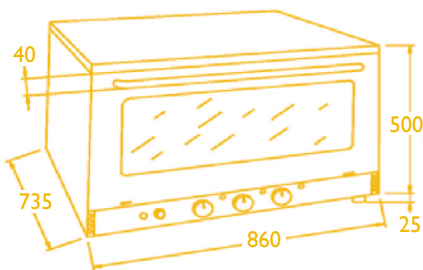

Brio Midi and Brio Maxi oven models stand out for their reliability and user-friendliness and are the most effective solution for those users who seek professional baking results even on small volumes.

	BRIO MIDI ⚡	BRIO MAXI ⚡
Voltage	230V(1ph) 50-60Hz	230V(1ph) 50-60Hz 400V(2ph+N) 50-60Hz
Power	3.2 kW	6.3 kW
Controls	electromechanical	electromechanical
Outside finishing	AISI430 stainless steel	AISI430 stainless steel
Inside finishing	AISI430 stainless steel	AISI430 stainless steel
No. of fans	1 (timed inversion)	2 (timed inversion)
Max. tray capacity and tray size	3 trays 600 x 400 mm. (included)	4 trays 600 x 400 mm. (included)
Tray interval	80 mm.	80 mm.
Max. working temperature	300°C	300°C
Timer	120 min.	120 min.
Humidification button	YES	YES
Dimensions (l x w x h)	860 x 775 x 525 mm.	860 x 775 x 605 mm.
Net weight	59 Kg.	68 Kg.
Packed dimensions and weight	950 x 860 x 640 mm. 67 Kg.	950 x 860 x 740 mm. 78 Kg.
Standard packing	export pallet box	export pallet box

Part numbers, models, descriptions and technical characteristics may be modified by IK-INTERKLIMAT S.p.A. without prior notification.



BRIOTEK

Each Briotek oven model can be equipped with matching **proofer**.

LIEV14

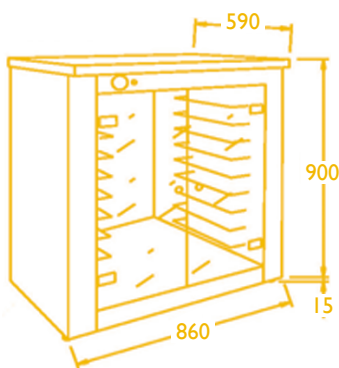

ACCESSORIES

600 x 400 mm. size aluminium trays:

- TEGI29** Level tray
- TEGI30** Silicone glazed level tray
- TEGI31** Teflon coated level tray
- TEGI34** Perforated level tray
- TEGI35** Perforated level tray - silicone glazed
- TEGI39** Perforated corrugated tray - 5 slots
- TEGI40** Perforated corrugated tray - 5 slots silicone glazed

600 x 400 mm. size grills:

- GRI295** Chromed grill

	LIEV14 ⚡
Voltage	230V(1 ph) 50-60Hz
Power	1.4 kW
Controls	electromechanical
Outside finishing	AISI430 stainless steel glass doors
Inside finishing	AISI430 stainless steel
Max. tray capacity and tray size	9 trays 600 x 400 mm. (not included)
Tray interval	70 mm.
Working temperature range	30 - 90°C
Dimensions (l x w x h)	860 x 590 x 915 mm.
Net weight	38 Kg.
Packed dimensions and weight	900 x 680 x 970 mm. - Kg. 41
Standard packing	carton on pallet



TEGI29



TEGI31



TEGI39

Part numbers, models, descriptions and technical characteristics may be modified by IK-INTERKLIMAT S.p.A. without prior notification.