



GASTROTEK

FEV60
FEV120

Gastrotek line features convection ovens designed for professional gastronomy offering the option of three different cooking procedures: **convection with humidification, steam, convection/steam combined.**

FEV60 and **FEV120** ovens - using **convection with humidification** - are highly reliable ovens for all basic gastronomy cooking practices such as roasting, frying, grilling, au gratin, etc. Digital versions (E) are equipped with **core probe**.

FEV60E



FEV120E



Both models are available in two versions:
Manual (M) electro-mechanical controls
Digital (E) digital controls



M **E**

FEV60

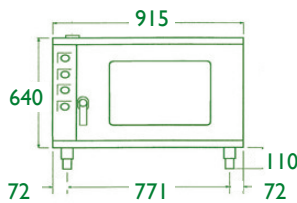

FEV120

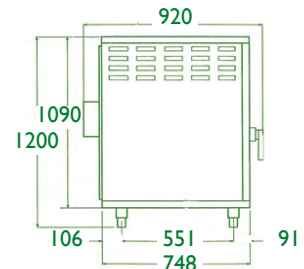
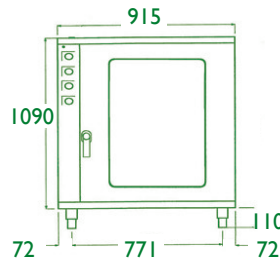
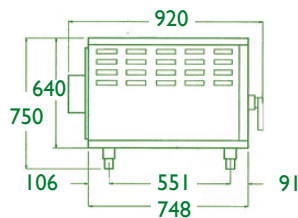

	FEV60 ⚡	FEV120 ⚡
Voltage	400V(3ph+N) 50-60Hz	400V(3ph+N) 50-60Hz
Power	7.9 kW	15.4 kW
Controls	M = Electromechanical - E = Digital	M = Electromechanical - E = Digital
Outside finishing	AISI430 stainless steel	AISI430 stainless steel
Inside finishing	AISI304 stainless steel	AISI304 stainless steel
No. of fans	1	1
Max. tray cap. and tray size	6 grills GN 1/1 mm. 530 x 325 (2 pcs. included)	12 grills GN 1/1 mm. 530 x 325 (2 pcs. included)
Tray interval	60 mm.	60 mm.
Core probe	on digital (E) version	on digital (E) version
Max. working temp.	270°C	270°C
Timer	120 min.	120 min.
Humidification	adjustable	adjustable
Dimensions (l x w x h)	915 x 920 x 750 mm.	915 x 920 x 1200 mm.
Net weight	96 Kg.	136 Kg.
Packed dimens. and weight	980 x 980 x 900 mm. - Kg. 112	980 x 980 x 1340 mm. - Kg. 156
Standard packing	export pallet box	export pallet box



GASTROTEK

Gastrotek line is completed by **warming cabinets** and by a **full range of accessories** available on request.



LIEV16

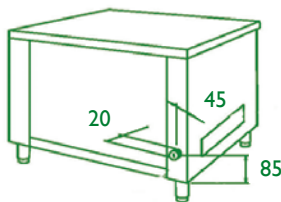
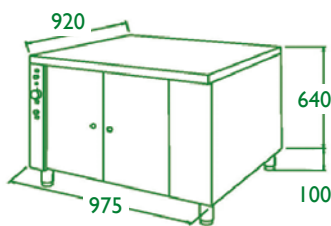

	LIEV15 ⚡	LIEV16 ⚡
Voltage	230V(1ph) 50-60Hz	230V(1ph) 50-60Hz
Power	1.4 kW	1.4 kW
Controls	electromechanical	electromechanical
Outside finishing	AISI430 stainless steel / glass doors	AISI430 stainless steel / steel doors
Inside finishing	AISI430 stainless steel	AISI430 stainless steel
Max. tray capacity and tray size	10 grills 1/1 GN mm. 530 x 325 (not included)	10 grills 1/1 GN mm. 530 x 325 (not included)
Tray interval	90 mm.	90 mm.
Working temp. range	30 - 90°C	30 - 90°C
Humidification button	YES	YES
Dimensions (l x w x h)	975 x 940 x 740 mm.	975 x 940 x 740 mm.
Net weight	52 Kg.	52 Kg.
Packed dimensions and weight	980 x 1010 x 900 mm. Kg. 70	980 x 1010 x 900 mm. Kg. 70
Standard packing	export pallet box	export pallet box

ACCESSORIES

SUP900 Gastrotek ovens open stand

SUP950 Tray holder for SUP900

DOC100 Shower

DVA001 Water softener

FIL200 Grease filter for 6 levels ovens

FIL210 Grease filter for 12 levels ovens

GN 1/1 size grills (530 x 325 mm.):

GR1288 Stainless steel grill

GR1350 Chicken grill (8 positions)

GN 1/1 size trays (530 x 325 mm.):

TEG227 Stainless steel tray - 20 mm. depth.

TEG228 Stainless steel tray - 65 mm. depth.

TEG229 Stainless steel tray - 40 mm. depth.

TEG360 French fries tray



SUP900 + 950



DVA001



DOC100



FIL200

"GIERRE" is a brandname of IK-INTERKLIMAT S.p.A.

IK-Interklimat

via Remigio Paone, 2 - 20153 Milano (Italy) - tel. +39.02.452817.1 - fax +39.02.48202850
e-mail: gierre@gierre.net - ovens@ikinterklimat.com



GASTROTEK

FEV6I
FEV12I

Gastrotek line features convection ovens designed for professional gastronomy offering the option of three different cooking procedures: **convection with humidification, steam, convection/steam combined.**

FEV6I and **FEV12I** ovens - using **convection with humidification** - are highly reliable ovens for all basic gastronomy cooking practices such as roasting, frying, grilling, au gratin, etc.

Digital versions (E) are equipped with **core probe**.

FEV6IE



FEV12IE



Both models are available in two versions:
Manual (M) electromechanical controls
Digital (E) digital controls



M

E

FEV6I

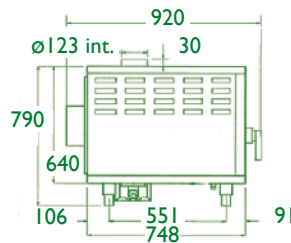
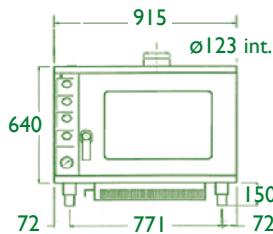

FEV12I

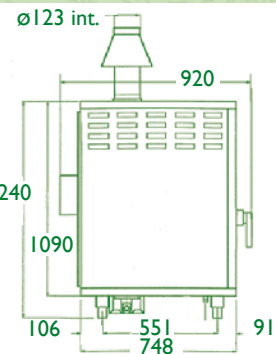
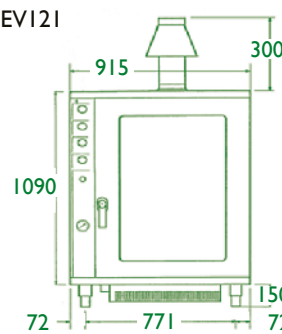

	FEV6I 🔥	FEV12I 🔥
Voltage	230V(1ph) 50Hz or on request 60Hz	230V(1ph) 50Hz or on request 60Hz
Power	0.4 kW	0.4 kW
Gas consumption (warm-up)	natural gas = G20 1.427 m ³ /h - LPG = G30 1.067 Kg/h	natural gas = G20 1.691 m ³ /h - LPG = G30 1.265 Kg/h
Controls	M = Electromechanical - E = Digital	M = Electromechanical - E = Digital
Outside finishing	AISI430 stainless steel	AISI430 stainless steel
Inside finishing	AISI304 stainless steel	AISI304 stainless steel
No. of fans	1	1
Max. tray cap. and tray size	6 grills GN 1/1 mm. 530 x 325 (2 pcs. included)	12 grills GN 1/1 mm. 530 x 325 (2 pcs. included)
Tray interval	60 mm.	60 mm.
Core probe	on digital (E) version	on digital (E) version
Max. working temperature	270°C	270°C
Timer	120 min.	120 min.
Humidification	adjustable	adjustable
Dimensions (l x w x h)	915 x 920 x 820 mm.	915 x 920 x 1240 mm.+ 300 wind - protection chimney
Net weight	111 Kg.	157 Kg.
Packed dim. and weight	980 x 980 x 980 mm. - Kg. 127	980 x 980 x 1400 mm. - Kg. 177
Standard packing	export pallet box	export pallet box

Part numbers, models, descriptions and technical characteristics may be modified by IK-INTERKLIMAT S.p.A. without prior notification.



GASTROTEK

Gastrotek line is completed by **warming cabinets** and by a **full range of accessories** available on request.



LIEVI6

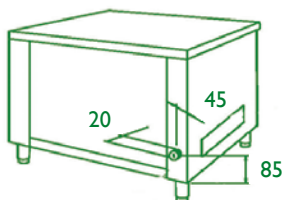
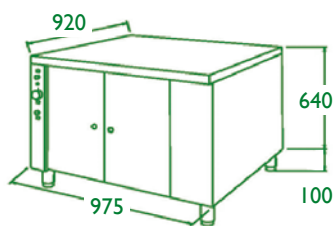

	LIEVI5 ⚡	LIEVI6 ⚡
Voltage	230V(1ph) 50-60Hz	230V(1ph) 50-60Hz
Power	1.4 kW	1.4 kW
Controls	electromechanical	electromechanical
Outside finishing	AISI430 stainless steel / glass doors	AISI430 stainless steel / steel doors
Inside finishing	AISI430 stainless steel	AISI430 stainless steel
Max. tray capacity and tray size	10 grills 1/1 GN mm. 530 x 325 (not included)	10 grills 1/1 GN mm. 530 x 325 (not included)
Tray interval	90 mm.	90 mm.
Working temp. range	30 - 90°C	30 - 90°C
Humidification button	YES	YES
Dimensions (l x w x h)	975 x 940 x 740 mm.	975 x 940 x 740 mm.
Net weight	52 Kg.	52 Kg.
Packed dimensions and weight	980 x 1010 x 900 mm. Kg. 70	980 x 1010 x 900 mm. Kg. 70
Standard packing	export pallet box	export pallet box

ACCESSORIES

- SUP900** Gastrotek ovens open stand
- SUP950** Tray holder for SUP900
- DOC100** Shower
- DVA001** Water softener
- FIL200** Grease filter for 6 levels ovens
- FIL210** Grease filter for 12 levels ovens

- GN 1/1 size grills (530 x 325 mm.):**
- GRI288** Stainless steel grill
 - GRI350** Chicken grill (8 positions)

- GN 1/1 size trays (530 x 325 mm.):**
- TEG227** Stainless steel tray - 20 mm. depth.
 - TEG228** Stainless steel tray - 65 mm. depth.
 - TEG229** Stainless steel tray - 40 mm. depth.
 - TEG360** French fries tray



SUP900 + 950



DVA001



DOC100



FIL200

"GIERRE" is a brandname of **IK-INTERKLIMAT S.p.A.**



via Remigio Paone, 2 - 20153 Milano (Italy) - tel. +39.02.452817.1 - fax +39.02.48202850
e-mail: gierre@gierre.net - ovens@ikinterklimat.com



GASTROTEK

FEV62
FEV122

Gastrotek line features convection ovens designed for professional gastronomy offering the option of three different cooking procedures: **convection with humidification, steam, convection/steam combined.**

FEV62 and **FEV122** ovens - with **direct steam generation** - enable their user to work with great flexibility and achieve the best cooking results coupled with equipment easiness of use and maintenance. All versions are equipped with **core probe.**

FEV62P



FEV122M



Both models are available in three versions: **Manual (M)** electromechanical controls, **Digital (E)** digital controls, **Programmable (P)** saving a maximum of 80 baking programs, each of them made up of max. 8 phases

FEV62

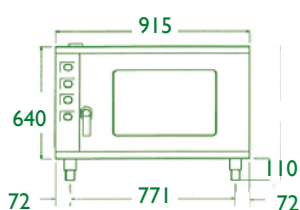

FEV122

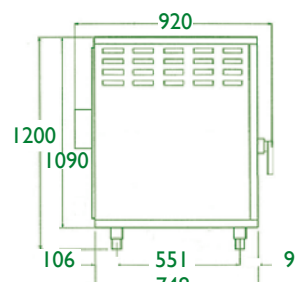
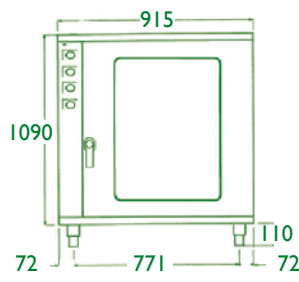
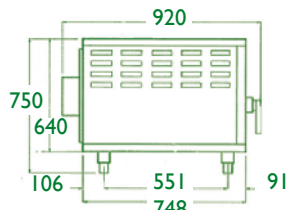

FEV62 ⚡

FEV122 ⚡

Voltage	400V(3ph+N) 50-60Hz	400V(3ph+N) 50-60Hz
Power	7.9 kW	15.4 kW
Controls	M = Electromechanical - E = Digital P = Programmable	M = Electromechanical - E = Digital P = Programmable
Outside finishing	AISI430 stainless steel	AISI430 stainless steel
Inside finishing	AISI304 stainless steel	AISI304 stainless steel
No. of fans	1	1
Max. tray cap. and tray size	6 grills GN 1/1 mm. 530 x 325 (2 pcs. included)	12 grills GN 1/1 mm. 530 x 325 (2 pcs. included)
Tray interval	60 mm.	60 mm.
Steam generation	direct	direct
Core probe	included on all versions	included on all versions
Max. working temperature	270°C	270°C
Timer	120 min.	120 min.
Humidification	adjustable on E and P versions	adjustable on E and P versions
Dimensions (l x w x h)	915 x 920 x 750 mm.	915 x 920 x 1200 mm.
Net weight	101 Kg.	140 Kg.
Packed dim. and weight	980 x 980 x 900 mm. - Kg. 117	980 x 980 x 1340 mm. - Kg. 160
Standard packing	export pallet box	export pallet box



GASTROTEK

Gastrotek line is completed by **warming cabinets** and by a **full range** of **accessories** available on request.



LIEVI6

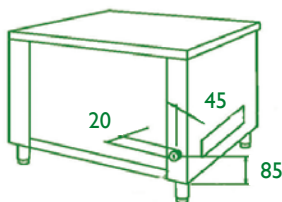
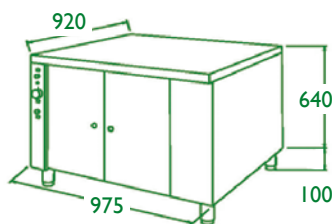

	LIEVI5 ⚡	LIEVI6 ⚡
Voltage	230V(1ph) 50-60Hz	230V(1ph) 50-60Hz
Power	1.4 kW	1.4 kW
Controls	electromechanical	electromechanical
Outside finishing	AISI430 stainless steel / glass doors	AISI430 stainless steel / steel doors
Inside finishing	AISI430 stainless steel	AISI430 stainless steel
Max. tray capacity and tray size	10 grills 1/1 GN mm. 530 x 325 (not included)	10 grills 1/1 GN mm. 530 x 325 (not included)
Tray interval	90 mm.	90 mm.
Working temp. range	30 - 90°C	30 - 90°C
Humidification button	YES	YES
Dimensions (l x w x h)	975 x 940 x 740 mm.	975 x 940 x 740 mm.
Net weight	52 Kg.	52 Kg.
Packed dimensions and weight	980 x 1010 x 900 mm. Kg. 70	980 x 1010 x 900 mm. Kg. 70
Standard packing	export pallet box	export pallet box

ACCESSORIES

- SUP900** Gastrotek ovens open stand
- SUP950** Tray holder for SUP900
- DOC100** Shower
- DVA001** Water softener
- FIL200** Grease filter for 6 levels ovens
- FIL210** Grease filter for 12 levels ovens

GN 1/1 size grills (530 x 325 mm.):

- GR1288** Stainless steel grill
- GR1350** Chicken grill (8 positions)

GN 1/1 size trays (530 x 325 mm.):

- TEG227** Stainless steel tray - 20 mm. depth.
- TEG228** Stainless steel tray - 65 mm. depth.
- TEG229** Stainless steel tray - 40 mm. depth.
- TEG360** French fries tray



SUP900 + 950



DVA001



DOC100



FIL200

Part numbers, models, descriptions and technical characteristics may be modified by IK-INTERKLIMAT S.p.A. without prior notification.



GASTROTEK

FEV63

FEV123

Gastrotek line features convection ovens designed for professional gastronomy offering the option of three different cooking procedures: **convection with humidification, steam, convection/steam combined.**

FEV63 and **FEV123** ovens - with **direct steam generation** - enable their user to work with great flexibility and achieve the best cooking results coupled with equipment easiness of use and maintenance.

All versions are equipped with **core probe.**

Both models are available in three versions:

Manual (M) electromechanical controls
Digital (E) digital controls
Programmable (P) saving a maximum of 80 baking programs, each of them made up of max. 8 phases



FEV63P



FEV123M



FEV63

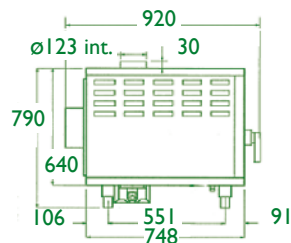
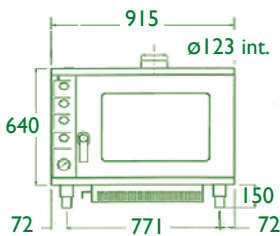

FEV123

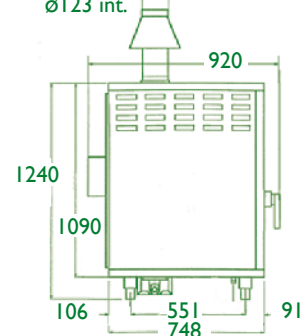
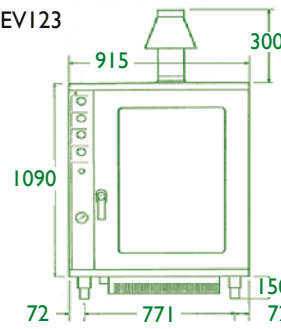

	FEV63 🔥	FEV123 🔥
Voltage	230V(1ph) 50Hz - or on request 60Hz	230V(1ph) 50Hz - or on request 60Hz
Power	0.4 kW	0.4 kW
Gas consumption (warm-up)	natural gas = G20 1.427 m ³ /h - LPG = G30 1.067 Kg/h	natural gas = G20 1.691 m ³ /h - LPG = G30 1.265 Kg/h
Controls	M = Electromechanical - E = Digital P = Programmable	M = Electromechanical - E = Digital P = Programmable
Outside finishing	AISI430 stainless steel	AISI430 stainless steel
Inside finishing	AISI304 stainless steel	AISI304 stainless steel
No. of fans	1	1
Max. tray cap. and tray size	6 grills GN 1/1 mm. 530 x 325 (2 pcs. included)	12 grills GN 1/1 mm. 530 x 325 (2 pcs. included)
Tray interval	60 mm.	60 mm.
Steam generation	direct	direct
Core probe	included on all versions	included on all versions
Max.working temperature	270°C	270°C
Timer	120 min.	120 min.
Humidification	adjustable on E and P versions	adjustable on E and P versions
Dimensions (l x w x h)	915 x 920 x 820 mm.	915 x 920 x 1240 mm.+300 mm. wind-protection chimney
Net weight	116 Kg.	162 Kg.
Packed dim. and weight	980 x 980 x 980 mm. - Kg. 132	980 x 980 x 1400 mm. - Kg. 182
Standard packing	export pallet box	export pallet box

Part numbers, models, descriptions and technical characteristics may be modified by IK-INTERKLIMAT S.p.A. without prior notification.



GASTROTEK

Gastrotek line is completed by **warming cabinets** and by a **full range of accessories** available on request.



LIEV16

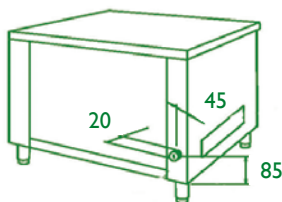
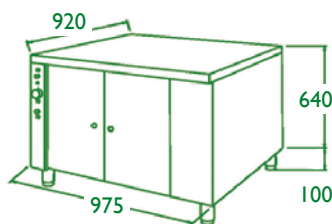

	LIEV15 ⚡	LIEV16 ⚡
Voltage	230V(1ph) 50-60Hz	230V(1ph) 50-60Hz
Power	1.4 kW	1.4 kW
Controls	electromechanical	electromechanical
Outside finishing	AISI430 stainless steel / glass doors	AISI430 stainless steel / steel doors
Inside finishing	AISI430 stainless steel	AISI430 stainless steel
Max. tray capacity and tray size	10 grills 1/1 GN mm. 530 x 325 (not included)	10 grills 1/1 GN mm. 530 x 325 (not included)
Tray interval	90 mm.	90 mm.
Working temp. range	30 - 90°C	30 - 90°C
Humidification button	YES	YES
Dimensions (l x w x h)	975 x 940 x 740 mm.	975 x 940 x 740 mm.
Net weight	52 Kg.	52 Kg.
Packed dimensions and weight	980 x 1010 x 900 mm. Kg. 70	980 x 1010 x 900 mm. Kg. 70
Standard packing	export pallet box	export pallet box

ACCESSORIES

- SUP900** Gastrotek ovens open stand
- SUP950** Tray holder for SUP900
- DOC100** Shower
- DVA001** Water softener
- FIL200** Grease filter for 6 levels ovens
- FIL210** Grease filter for 12 levels ovens

GN 1/1 size grills (530 x 325 mm.):

- GR1288** Stainless steel grill
- GR1350** Chicken grill (8 positions)

GN 1/1 size trays (530 x 325 mm.):

- TEG227** Stainless steel tray - 20 mm. depth.
- TEG228** Stainless steel tray - 65 mm. depth.
- TEG229** Stainless steel tray - 40 mm. depth.
- TEG360** French fries tray



SUP900 + 950



DVA001



DOC100



FIL200

Part numbers, models, descriptions and technical characteristics may be modified by IK-INTERKLIMAT S.p.A. without prior notification.



GASTROTEK

FEV64

FEV124

Gastrotek line features convection ovens designed for professional gastronomy offering the option of three different cooking procedures: **convection with humidification, steam, convection/steam combined.**

FEV64 and **FEV124** ovens - with **boiler steam generation** - are thorough and versatile working tools granting to the user a surprisingly wide range of cooking possibilities in consideration of their cost-effectiveness. All versions are equipped with **core probe.**

FEV124M

FEV64P



Both models are available in three versions:
Manual (M) electromechanical controls
Digital (E) digital controls
Programmable (P) saving a maximum of 80 baking programs, each of them made up of max. 8 phases

M

E

P



Part numbers, models, descriptions and technical characteristics may be modified by IK-INTERKLIMAT Sp.A. without prior notification.

FEV 64

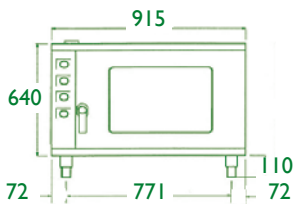

FEV 124

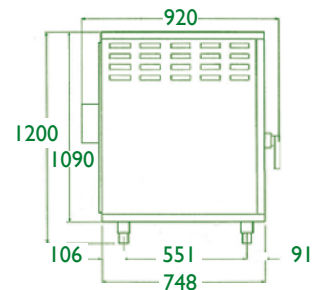
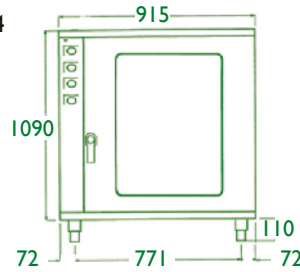
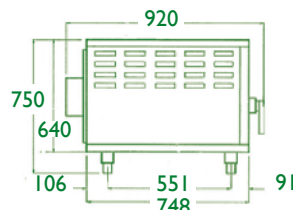

	FEV64 ⚡	FEV124 ⚡
Voltage	400V(3ph+N) 50-60Hz	400V(3ph+N) 50-60Hz
Power	9.2 kW	18 kW
Controls	M = Electromechanical - E = Digital P = Programmable	M = Electromechanical - E = Digital P = Programmable
Outside finishing	AISI430 stainless steel	AISI430 stainless steel
Inside finishing	AISI304 stainless steel	AISI304 stainless steel
No. of fans	1	1
Max. tray cap. and tray size	6 grills GN 1/1 mm. 530 x 325 (2 pcs. included)	12 grills GN 1/1 mm. 530 x 325 (2 pcs. included)
Tray interval	60 mm.	60 mm.
Steam generation	boiler	boiler
Core probe	included on all versions	included on all versions
Max. working temperature	270°C	270°C
Timer	120 min.	120 min.
Humidification	adjustable on E and P versions	adjustable on E and P versions
Dimensions (l x w x h)	915 x 920 x 750 mm.	915 x 920 x 1200 mm.
Net weight	104 Kg.	146 Kg.
Packed dim. and weight	980 x 980 x 900 mm. - Kg. 120	980 x 980 x 1340 mm. - Kg. 166
Standard packing	export pallet box	export pallet box



GASTROTEK

Gastrotek line is completed by **warming cabinets** and by a **full range of accessories** available on request.



LIEV16

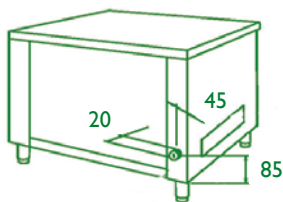
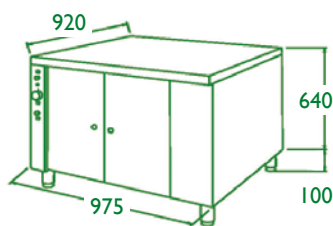

	LIEV15 ⚡	LIEV16 ⚡
Voltage	230V(1ph) 50-60Hz	230V(1ph) 50-60Hz
Power	1.4 kW	1.4 kW
Controls	electromechanical	electromechanical
Outside finishing	AISI430 stainless steel / glass doors	AISI430 stainless steel / steel doors
Inside finishing	AISI430 stainless steel	AISI430 stainless steel
Max. tray capacity and tray size	10 grills 1/1 GN mm. 530 x 325 (not included)	10 grills 1/1 GN mm. 530 x 325 (not included)
Tray interval	90 mm.	90 mm.
Working temp. range	30 - 90°C	30 - 90°C
Humidification button	YES	YES
Dimensions (l x w x h)	975 x 940 x 740 mm.	975 x 940 x 740 mm.
Net weight	52 Kg.	52 Kg.
Packed dimensions and weight	980 x 1010 x 900 mm. Kg. 70	980 x 1010 x 900 mm. Kg. 70
Standard packing	export pallet box	export pallet box

ACCESSORIES

- SUP900** Gastrotek ovens open stand
- SUP950** Tray holder for SUP900
- DOC100** Shower
- DVA001** Water softener
- FIL200** Grease filter for 6 levels ovens
- FIL210** Grease filter for 12 levels ovens

GN 1/1 size grills (530 x 325 mm.):

- GRI288** Stainless steel grill
- GRI350** Chicken grill (8 positions)

GN 1/1 size trays (530 x 325 mm.):

- TEG227** Stainless steel tray - 20 mm. depth.
- TEG228** Stainless steel tray - 65 mm. depth.
- TEG229** Stainless steel tray - 40 mm. depth.
- TEG360** French fries tray



SUP900 + 950



DVA001



DOC100



FIL200

"GIERRE" is a brandname of **IK-INTERKLIMAT S.p.A.**

IK-Interklimat

via Remigio Paone, 2 - 20153 Milano (Italy) - tel. +39.02.452817.1 - fax +39.02.48202850
e-mail: gierre@gierre.net - ovens@ikinterklimat.com